



## Peterborough City Hospital

### Heating and Cooling for Hospitals glass foyer

Peterborough's 612 bed, four storey, multimillion pound City Hospital, built on the site of the former Edith Cavell Hospital, has brought a better all round health service to the City. The building is the largest building project in the city since Peterborough Cathedral was built over 800 years ago.

The well thought out layout and comfort of the building was a high priority during the design stage, with visitors comfort and ease at the forefront of the spec. This can be seen from numerous features throughout the building including the hospitals glass atrium reception area. Where the comfort of the visitors wait was paramount.

Thermo-Floor were awarded this contract by the Mechanical Contractor.

It was decided that a combined underfloor heating or cooling system was the ideal solution to ensure a constant temperature could be maintained in all seasons. The cooling particularly needed during the summer months to absorb the high levels of solar gain from the large glass roof.

#### Facts and Figures

##### Building

- Floor area : 974 m<sup>2</sup>
- Insulation: 0.029 W/m.k
- Floor insulation: 974 m<sup>2</sup>

##### Source of energy

- Boiler and Chiller

##### Climate system

- Heating and Cooling
- Active heating up to 50°C flow
- Active cooling down to 18°C flow

##### Thermo-Floor system

- Full service project execution
- RU-WK manifolds for heating and cooling
- Central control for each zone with averaging sensors
- 4.1 miles underfloor pipe

A Thermo-Floor Project Manager oversaw each stage of the project, which took 12 days to complete. And covered an area of 974 m<sup>2</sup>, across 64 heating loops, using 6,818m ( 4.1miles) our 20x3.4mm UFH tube.

### Peterborough Hospital



The design of Peterborough’s new multi million pound city hospital has not only delivered a better health service to the public but has given the patrons a more comfortable wait in the reception area with simultaneous underfloor heating or cooling.

Thermo-Floor were contracted by Mercury Engineering for the project. Thermo-Floor installed their unique manifold, the RUW-K to provide simultaneous underfloor heating or cooling. This manifold works with both a heat and cooling source, for example a boiler and a chiller. This ensures the waiting area is not affected by solar gain from the glass roofed atrium and therefore maintaining the room temperature in all seasons.

The RU-VK manifold is used with a water supply temperature of 50°C or greater for heating and pre regulated 18°C for cooling. The manifold is factory pre-assembled, pressure tested to 700kPa and epoxy coated. The cooling circuit must have a pre-regulated flow to the manifold. The manifold ranges in size from 2-20 loops. The pre-assembled manifold comes complete with: welded support brackets, rubber shock absorbers, circulation pump, temperature gauge on return header pressure/temperature gauge on flow header, thermostatic valve complete with temperature probe into flow header, high limit thermostat linked to the primary valve and condensation sensor (which will close the primary cooling circuit should condensation become detected). Each manifold floor loop contains isolation valves for manual electric actuation on the return header and isolation ball valves on the flow header.

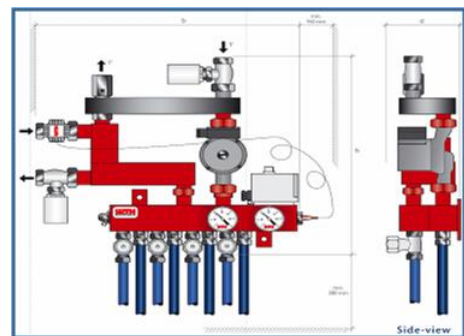

Dimension	H	W	D	Dimension	H	W	D
6	660	590	180	14	680	1050	180
7	680	630	180	15	680	1110	180
8	680	690	180	16	700	1180	180
9	680	750	180	17	700	1290	180
10	680	810	180	18	700	1350	180
11	680	870	180	19	700	1410	180
12	680	930	180	20	700	1470	180
13	680	990	180				